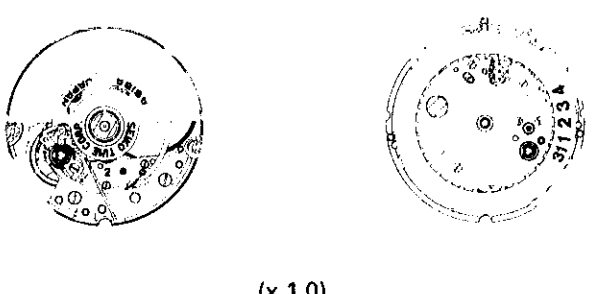

PARTS CATALOGUE / TECHNICAL GUIDE

Cal. 4S15A

[SPECIFICATIONS]

Item		Cal. No.	4S15A
Movement		 <p>(x 1.0)</p>	
Movement size	Outside diameter	ø26.0 mm	
	Casing diameter	ø25.6 mm	
	Height	4.17 mm	
Time indication		Three hands (Hour, minute and second hands)	
Vibrations per hour		28,800 (8 beats per second)	
Additional mechanism		<ul style="list-style-type: none"> • Automatic winding (with auxiliary hand winding mechanism) • Date calendar • Second setting device • Micro-regulating device • Regulating device by micro-positioning regulator pin 	
Jewels		25 jewels	

SEIKO CORPORATION

PARTS CATALOGUE

Cal. 4S15A

Disassembling procedures Figs. : (1) ~ (58)

Reassembling procedures Figs. : (58) ~ (1)

Lubricating: Types of oil

- ◀▶ Moebius V
- ▶ Moebius A
- ⊙▶ SEIKO Watch Oil S-6
- ▶ SEIKO Watch Oil S-4
- ▣▶ SEIKO Watch Oil S-3

Oil quantity

- ∞▶ Liberal quantity
- ◊▶ Normal quantity
- ◊▶ Extremely small

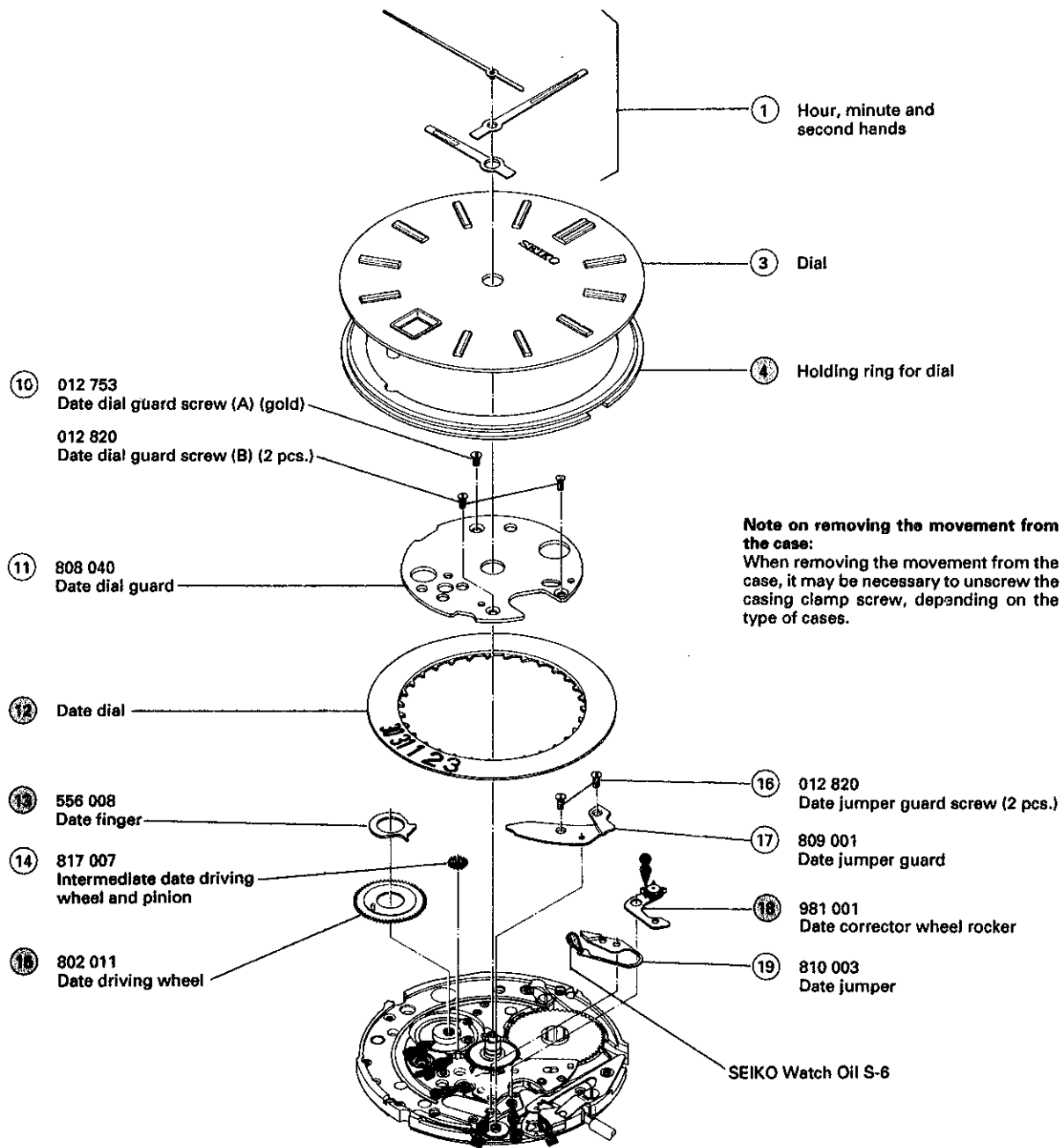

Note on removing the movement from the case:
When removing the movement from the case, it may be necessary to unscrew the casing clamp screw, depending on the type of cases.

➡ Please see the remarks on the following pages.

PARTS CATALOGUE

Cal. 4S15A

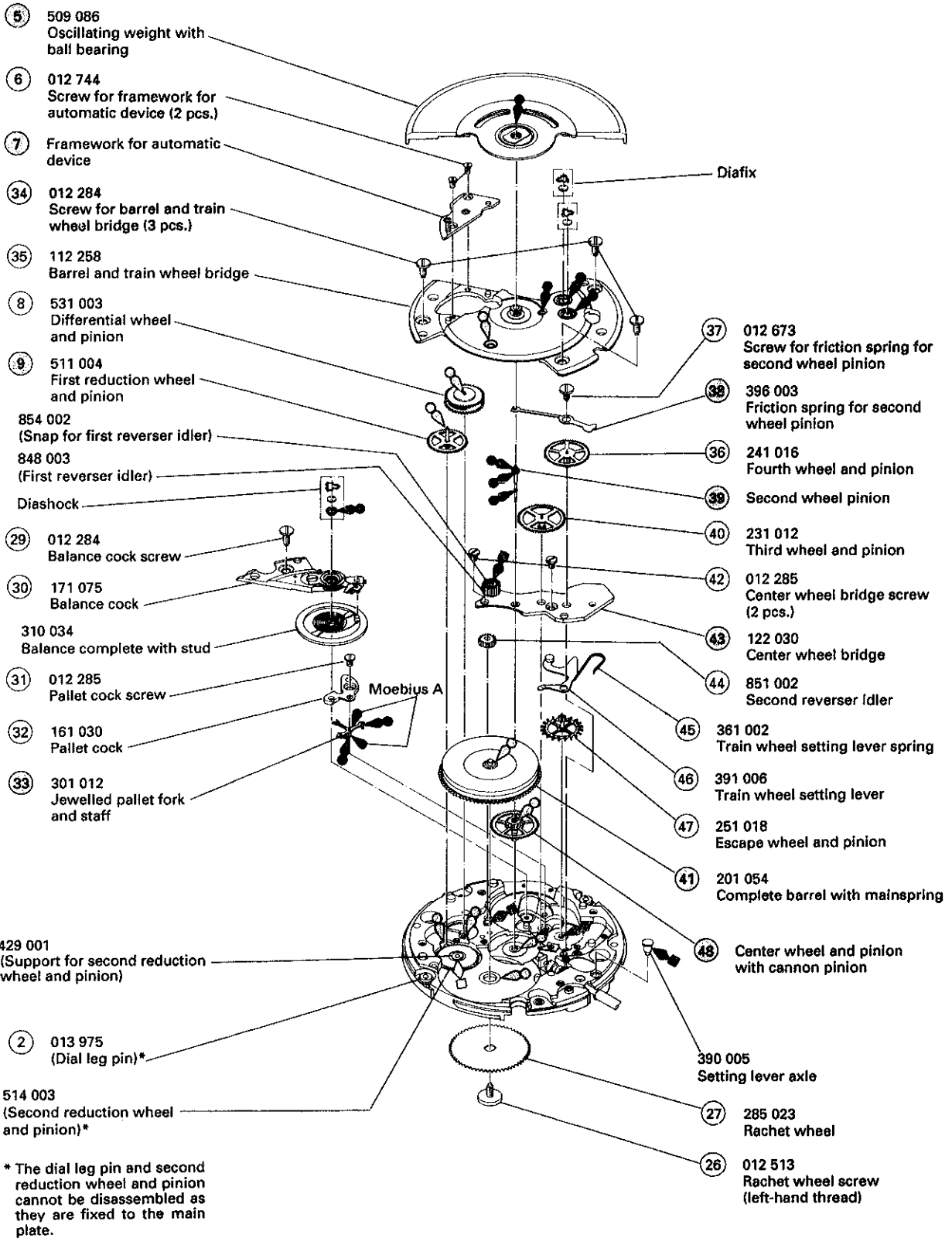

➡ Please see the remarks on the following pages.

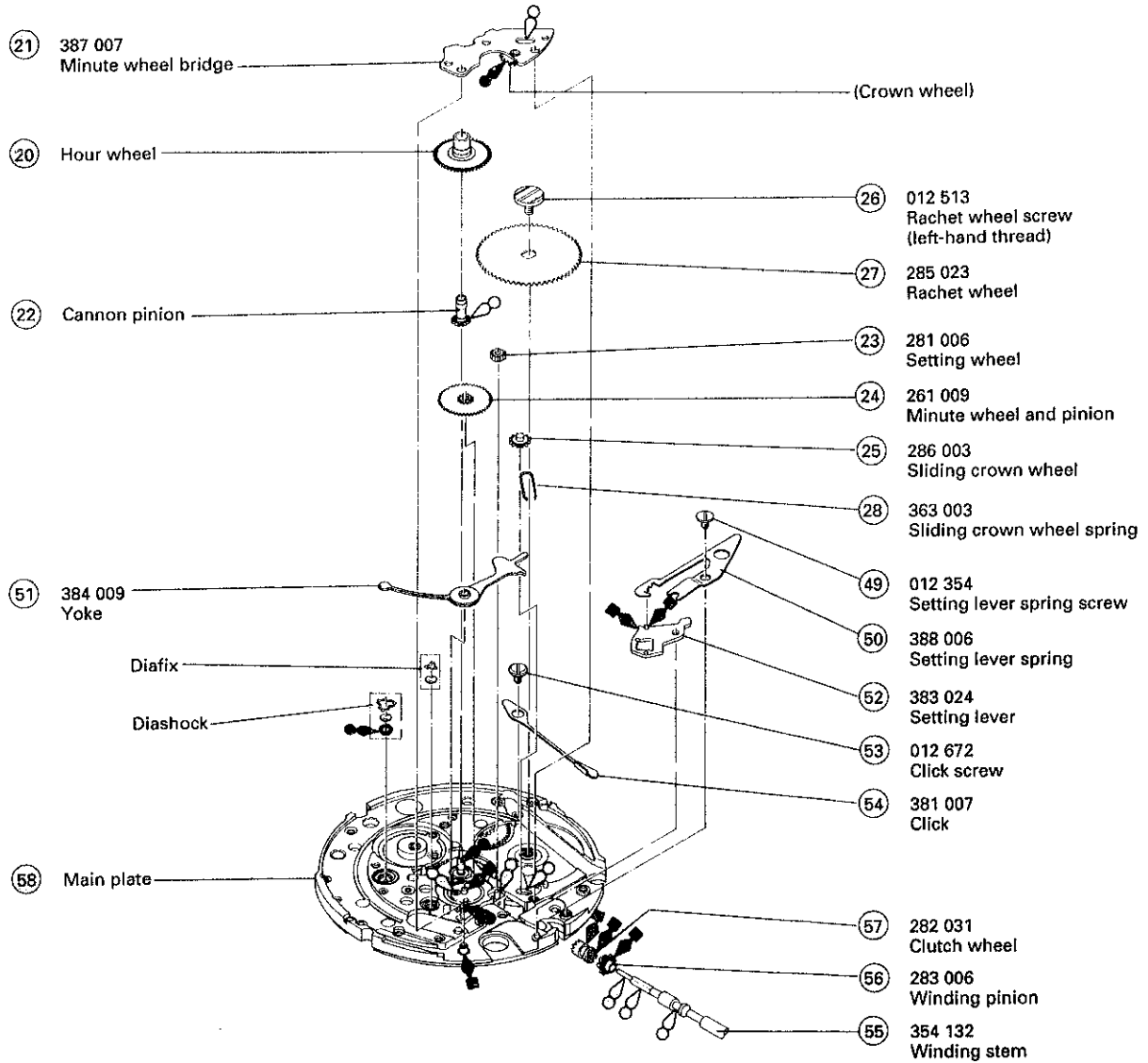

Please see the remarks on the following pages.

PARTS CATALOGUE

Cal. 4S15A

• List of screws

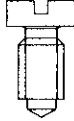
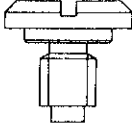
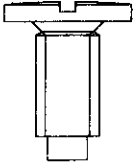
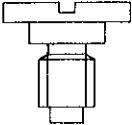
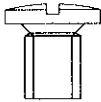
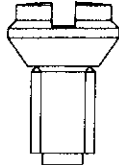
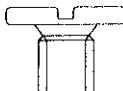
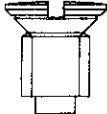
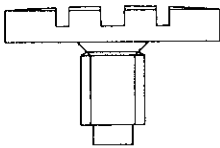
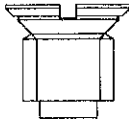
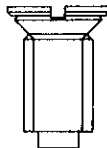
Part No.	Name	Part No.	Name
 012 121	<ul style="list-style-type: none"> • Stud screw 	 012 672	<ul style="list-style-type: none"> • Click screw
 012 284	<ul style="list-style-type: none"> • Screw for barrel and train wheel bridge • Balance cock screw 	 012 673	<ul style="list-style-type: none"> • Screw for friction spring for second wheel pinion
 012 285	<ul style="list-style-type: none"> • Center wheel bridge screw • Pallet cock screw 	 012 726	<ul style="list-style-type: none"> • Casing clamp screw
 012 354	<ul style="list-style-type: none"> • Setting lever spring screw 	 012 744	<ul style="list-style-type: none"> • Screw for framework for automatic device
 012 513	<ul style="list-style-type: none"> • Ratchet wheel screw 	 012 753	<ul style="list-style-type: none"> • Date dial guard screw (A)
		 012 820	<ul style="list-style-type: none"> • Date dial guard screw (B) • Date jumper guard screw

PARTS CATALOGUE

Cal. 4S15A

• List of jewels

Part No.	Name	Part No.	Name
011 221	• Diashock upper/lower cap jewel	011 540	• Upper/lower hole jewel for third wheel and pinion
	• Diafix upper cap jewel for fourth wheel and pinion	011 584	• Lower hole jewel for fourth wheel and pinion
	• Diafix upper/lower cap jewel for escape wheel and pinion	011 505	• Upper/lower hole jewel for jewelled pallet fork and staff
011 398	• Upper hole jewel for complete barrel with mainspring	011 151	• Upper/lower hole jewel for first reduction wheel and pinion
011 715	• Upper hole jewel for center wheel and pinion	011 422	• Upper hole jewel for differential wheel and pinion
011 146	• Lower hole jewel for center wheel and pinion	011 157	• Lower hole jewel for differential wheel and pinion

• List of tubes and pins

Part No.	Name	Part No.	Name
013 026	• Tube for date corrector wheel rocker	032 127	• Tube for setting lever spring
013 934	• Micro adjuster pin	032 132	• Tube for casing clamp
013 975	• Dial leg pin		

• Other parts

Part No.	Name	Part No.	Name
315 021	• Balance staff	014 317	• Diashock upper/lower spring
331 005	• Roller with jewel	014 417	• Diafix upper spring for fourth wheel and pinion
341 016	• Regulator		• Diafix upper spring for escape wheel and pinion
344 080	• Regulator pointer	014 634	• Diashock lower frame
345 010	• Stud holder	015 513	• Diafix lower spring for escape wheel and pinion
399 007	• Casing clamp	015 551	• Diafix upper hole jewel with frame for fourth wheel and pinion
468 003	• Lower hole jewel with frame for jewelled pallet fork and staff	015 161	• Diafix upper hole jewel with frame for escape wheel and pinion
014 603	• Diashock upper frame	015 531	• Diafix lower hole jewel with frame for escape wheel and pinion
014 605	• Diashock upper/lower hole jewel with frame		

PARTS CATALOGUE





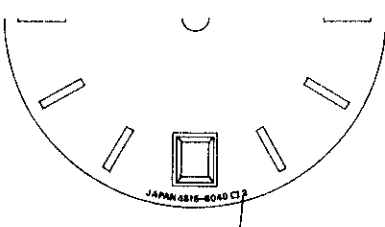
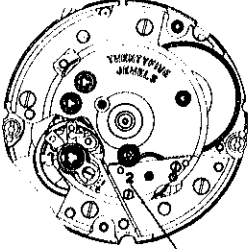

Cal. 4S15A

- ⑦ Framework for automatic device
- ⑳ Hour wheel
- ㉑ Second wheel pinion
- ㉒ Center wheel and pinion

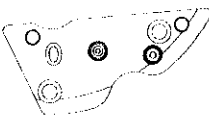
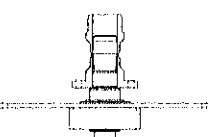
• **Discrimination of the hand installation height**

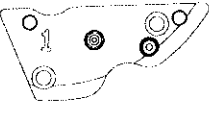
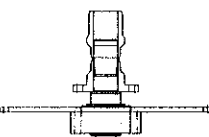
Cal. 4S15A watches have numerals printed on the dial and movement to indicate the hand installation height. When repairing, refer to the table below.

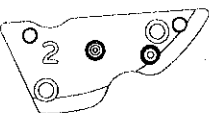
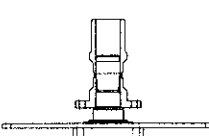
Discrimination	Height	Standard type	Standard type
	Numeral for discrimination	2	2
	Printed on	Dial	Movement
Printed position		Ex.) Standard type  The numeral is printed at the right end.	Ex.) Standard type  The numeral is printed on the movement.

Numeral for discrimination	Framework for automatic device	Center wheel and pinion with cannon pinion	Second wheel pinion	Hour wheel
0	 191 015	 224 035	 245 015	 271 310
1	 191 016	 224 034	 245 014	 271 306
2	 191 017	 224 036	 245 016	 271 311

④ Holding ring for dial

The type of holding ring for dial is determined based on the design of cases. Check the case number and refer to "SEIKO Casing Parts Catalogue" to choose a corresponding holding ring for dial.

⑫ Date dial

The type of date dial is determined based on the design of cases. Check the case number and refer to "SEIKO Casing Parts Catalogue" to choose a corresponding date dial.

TECHNICAL GUIDE

- The explanation here is only for the particular points of Cal. 4S15A.

I. REMARKS ON DISASSEMBLING AND REASSEMBLING

⑤ Oscillating weight with ball bearing

- **How to remove and install**

A screwdriver having a tip as shown in the illustration below is convenient for removing or installing the oscillating weight with ball bearing.



⑨ First reduction wheel and pinion

- **How to remove**

Before removing the first reduction wheel and pinion, be sure to unwind the mainspring. To do so, move the click in the direction of the arrow with tweezers as shown in the illustration below while turning the crown gently counterclockwise. If the click is moved without turning the crown counterclockwise, the mainspring will be unwound forcibly all at once and may cause the mainspring to be damaged.

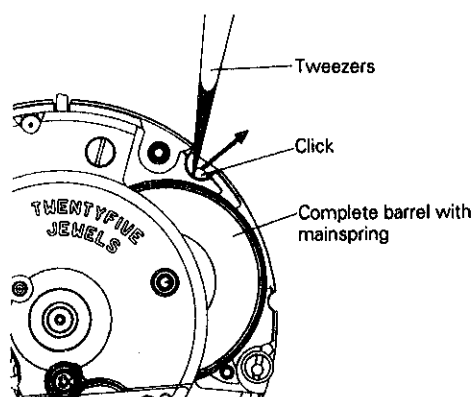

⑬ Date finger

⑮ Date driving wheel

• **How to install**

Set the date finger and date driving wheel as shown in the illustration below.

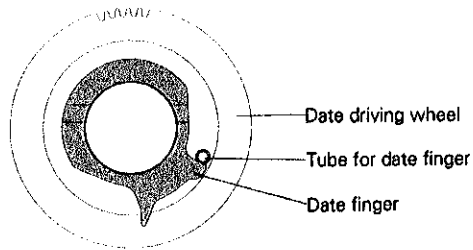

⑱ Date corrector wheel rocker

• **Lubricating**

After lubricating the portion indicated in the illustration below give the wheel gear of the date corrector wheel rocker 3 or 4 full turns so that the oil reaches every part of the gear shaft.

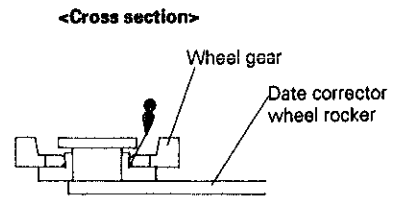
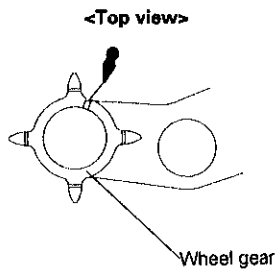

⑳ Minute wheel bridge

• **Lubricating**

Lubricate the crown wheel of the minute wheel bridge at the portion indicated in the illustration below.

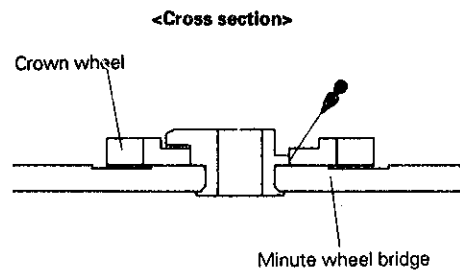
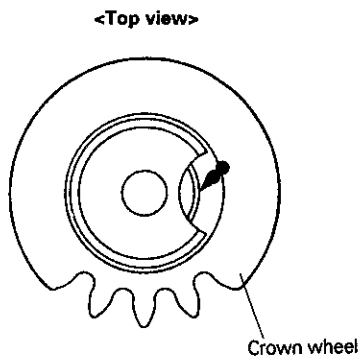

33 Jewelled pallet fork and staff

• Lubricating

Lubricate the jewelled pallet fork and staff at the portion indicated in the illustration below. When doing so, do not apply more oil than required or apply it to any other portion than specified, lest the oil should drip.

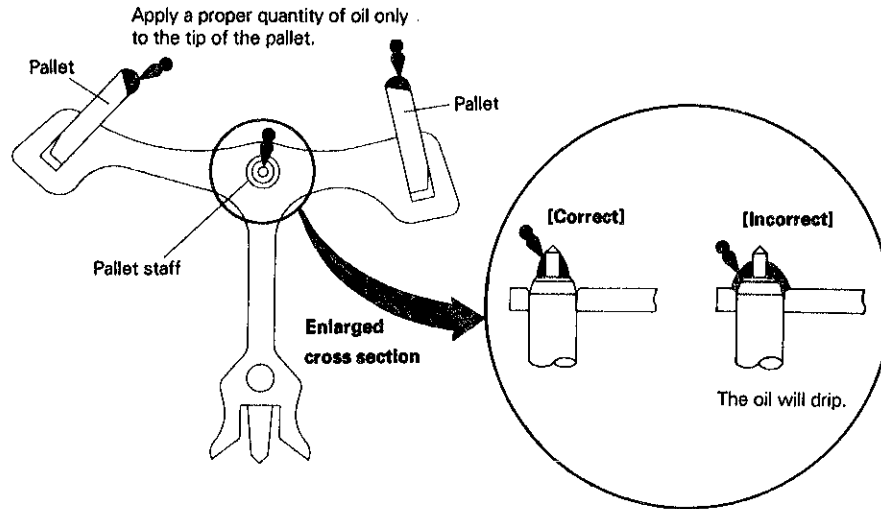

38 Friction spring for second wheel pinion

• How to install

Do not set the friction spring to the second wheel pinion from above the pinion portion, as the spring will not fit in position. Instead, insert the spring from sideways as shown in the illustration. After installing it, check if it is set in position.

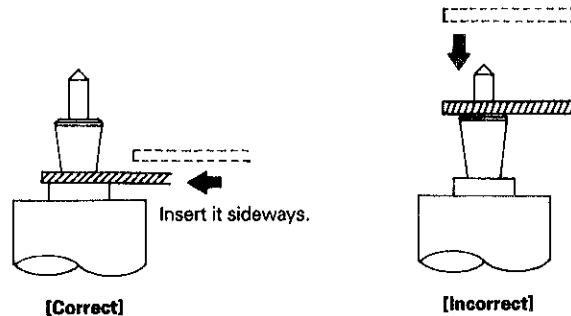

39 Second wheel pinion

• Lubricating

Lubricate the upper portion of the second wheel pinion as shown in the illustration below.

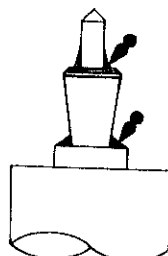

④① Complete barrel with mainspring

• Lubricating

It is not necessary to disassemble the complete barrel with mainspring. If it is disassembled for cleaning purposes, lubricate 2 to 3 portions inside the barrel with SEIKO Watch Oil S-3.

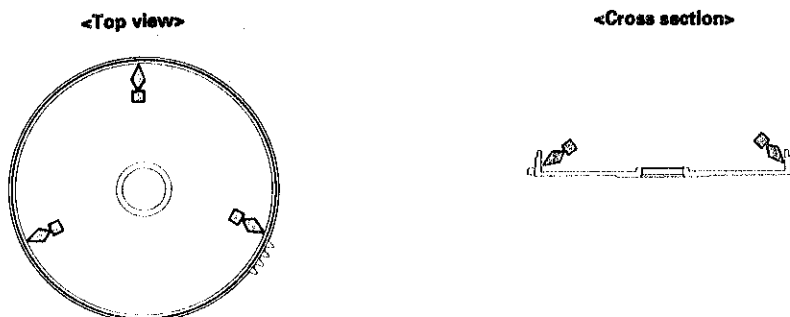

④③ Center wheel bridge

• Lubricating

Lubricate the first reverser idler of the center wheel bridge at the portion indicated in the illustration below.

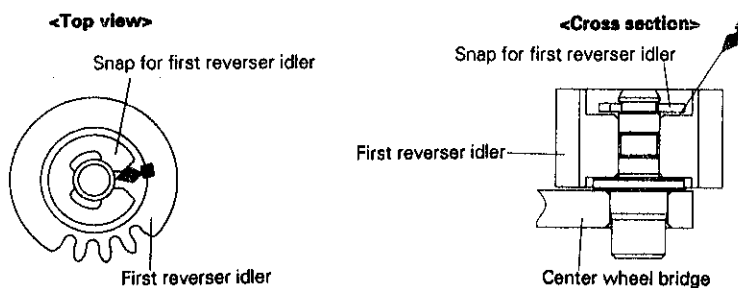

⑤⑧ Main plate

• Lubricating

Lubricate the second reduction wheel at the portion indicated in the illustration below.

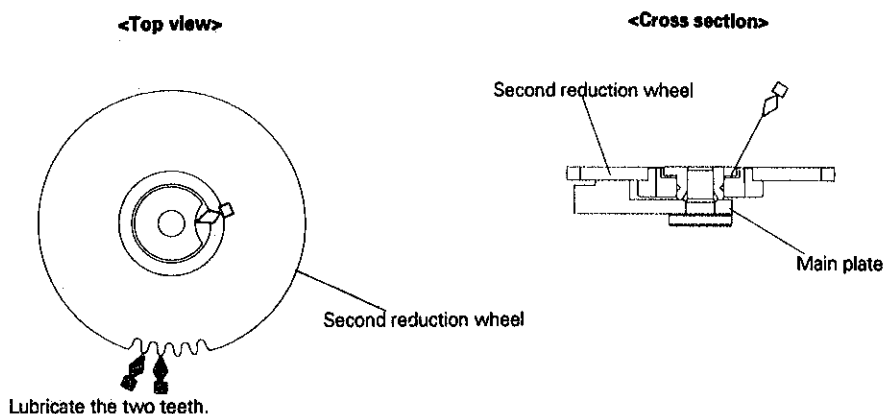

II. REFERENCE

• Date correction mechanism (with the crown at the first click)



Date dial
 (By turning the crown clockwise.)
 Free
 (By turning the crown counterclockwise.)

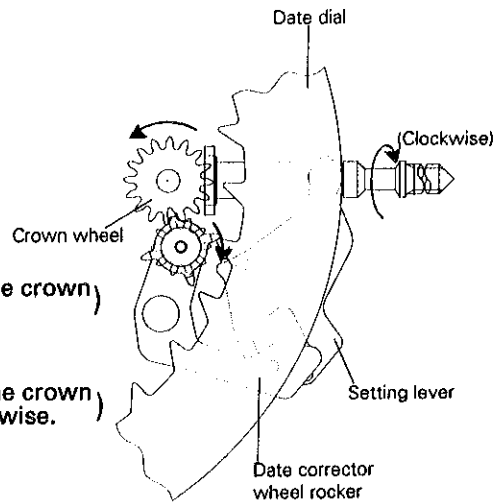

• How to wind the mainspring

• Manual winding mechanism

By turning the crown clockwise while the winding pinion and sliding crown wheel engage with each other (while the crown is at the normal or first click position), the ratchet wheel will turn intermediately by the sliding crown wheel, thus winding the mainspring. By turning the crown counterclockwise, however, the winding pinion will be disengaged from the sliding crown wheel, and the mainspring will not be wound. The winding pinion and sliding crown wheel are also disengaged when the mainspring is wound through the automatic winding mechanism.

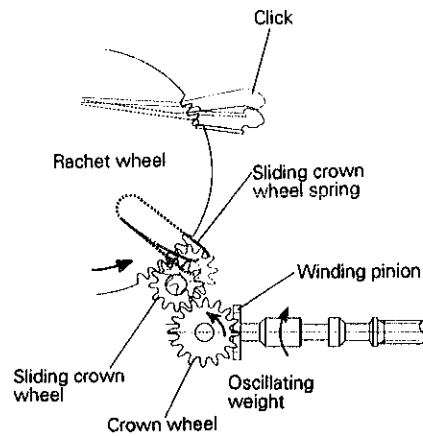

• Automatic winding mechanism

Regardless of whether the oscillating weight turns clockwise or counterclockwise, the differential wheel and pinion keeps the wheels turning only in one fixed direction so that the mainspring will be wound as the oscillating wheel turns.

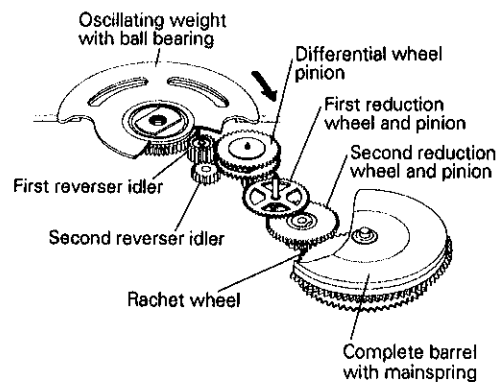
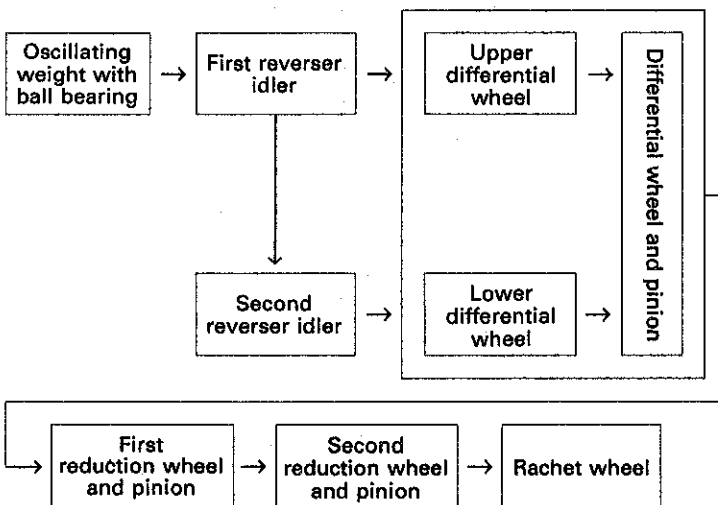

- **Second setting device**

When the crown is pulled out to the second click, the pin at the end of the train wheel setting lever presses down the balance complete with stud, thus stopping the hands.

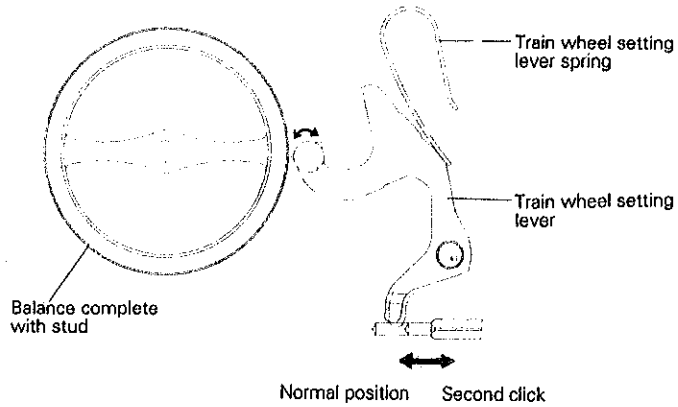

- **Regulating device by micro-positioning regulator pin**

The accuracy of the watch can be adjusted by moving the lever attached to the regulator device as shown in the illustration to extend or reduce the clearance between the regulator key and regulator pin. After replacing the balance complete with stud, be sure to adjust the accuracy using the lever. Except in such a case, however, do not move the lever, as the accuracy of the watch has been adjusted at the factory before shipment.

